

# 746M SERIES

1-800-826-5890 USA  
1-888-675-5483 Canada  
www.pauluhn.com

122



Lamp Suspension System

## FEATURES

- ▼ Unique lamp suspension system:
  - Advanced spring design allows springs to compress and counter which absorbs more vibration to extend lamp life.
  - Extends lamp life up to 50% longer than competitive brands.
- ▼ Adjustable universal mounting allows flexible positioning through 360° horizontally, vertically down 45° and up to 90° without handle.
- ▼ Choice of corrosion resistant housings in rugged heavy wall cast brass or cast aluminum.
- ▼ Sealed beam 500w quartz halogen or 300w incandescent lamp options.
- ▼ Medium floodlight as standard with narrow or wide beam pattern options.
- ▼ High Impact protective guard available to prevent damage to lamps and lens.
- ▼ Range of colored lenses available in red, blue, green and yellow.
- ▼ 5 year warranty.

## APPROVALS

- ▼ UL 1598A - Marine Outside Type Saltwater
- ▼ ABS
- ▼ Type 4X
- ▼ Conforms to IP 66

## APPLICATIONS

- ▼ Marine and wet environments
- ▼ Military ships
- ▼ Drill ships and exploration vessels
- ▼ Tankers
- ▼ Patrol boats
- ▼ Coast Guard rescue vessels

## OPTIONS

To obtain a fixture with any of the options listed below, please add the following suffix to the part number (not all options can be combined):

- |                                     |       |
|-------------------------------------|-------|
| ▼ Guard                             | GRD   |
| ▼ Narrow Spot Light Type            | NSP*  |
| ▼ Wide Floodlight Type              | WFL*  |
| ▼ Handle and Clamp                  | HDL   |
| ▼ 12v Medium Floodlight Type (300w) | -12   |
| ▼ 28v Medium Floodlight Type (450w) | -28** |
| ▼ Red Colored Lens                  | RED   |
| ▼ Blue Colored Lens                 | BLU   |
| ▼ Green Colored Lens                | GRN   |
| ▼ Yellow Colored Lens               | YEL   |

\* For 120v only.

\*\* Has 10 hour lamp life.

## DIMENSIONS

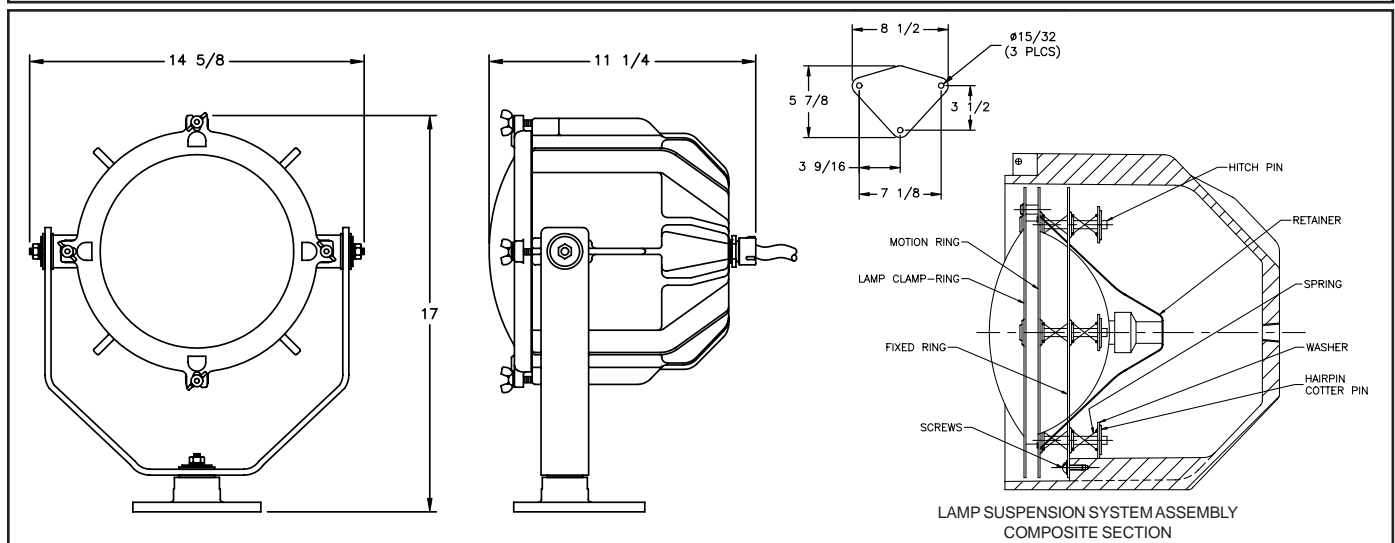

Dimensions in inches

**MARINE, OUTSIDE AND CORROSIVE ENVIRONMENTS  
WATERTIGHT SHOCK AND VIBRATION PROOF  
INCANDESCENT AND HALOGEN FLOODLIGHTS**



**TECHNICAL SPECIFICATION**

**HOUSING**

Available in heavy wall cast brass with a natural finish or a cast aluminum with an oven-cured white polyester powder coated protective finish.

**GUARD**

Optional stainless steel wire guard available.

**OUTLETS**

All units are supplied drilled and tapped with one 1/2" NPT outlet as standard complete with terminal tube and six feet of 16/3 cable. As an option, can be supplied with up to one 3/4" NPT outlet.

**HARDWARE**

Stainless steel wing nuts for all types.

**LENS**

Clear heat resistant glass lens.

**LAMP SUSPENSION SYSTEM**

Spring design assembly.

**TERMINAL BLOCK**

A 2 pole terminal block is provided as standard.

**VOLTAGE OPERATION**

Rated for operation on 120v as standard, 12v and 28v units are available.

**GASKETS**

One continuous piece silicone gasket provides an effective seal between the lens and housing.

**LAMP TYPE**

A 120v medium floodlight PAR56 lamp is supplied as standard. See options if narrow, wide or low voltage lamps are required. A 12v 300w or 28v 450w medium floodlight lamp is supplied with the low voltage version. 450w has 10 hour lamp life.

**LAMPHOLDER**

Mogul end prong porcelain lampholders with high temperature leads are supplied as standard. 12v and 28v low voltage units are supplied with screw terminal lamps wired via high temperature leads direct to the lamp.

**ORDERING REFERENCES**

**FLOODLIGHT FIXTURES**

DESCRIPTION	BRONZE WEIGHT (lbs)	BRASS TYPE (B)	ALUMINUM TYPE (A)	ALUMINUM WEIGHT (lbs)
300W Incandescent	56.0	746BMR	746AMR	22.0
500w Quartz Halogen	56.0	746BQMR	746AQMR	22.0

**SPARE PARTS**

<b>LAMPHOLDER</b>	INX4014	<b>LAMPS</b>	
<b>GUARD</b>	INX1041	300w MFL 120v	INX3509
<b>FRAME GASKET</b>	GKT6095	300w NSP 120v	INX3510
<b>LENS</b>	INX2143	300w WFL 120v	INX3581
<b>LENS AND FRAME ASSEMBLY</b>		500w MFL 120v	INX3511
Bronze	INX9037B	500w NSP 120v	INX3582
Aluminum	INX9037A	500w WFL 120v	INX3583
<b>STANDARD MOUNT</b>		300w MFL 12v	INX3576
Bronze	INX7048B	450w MFL 28v (10 hour lamp life)	INX3575
Aluminum	INX7048A	<b>TERMINAL BLOCK</b>	FX3001
<b>SWING BOLT/NUT KIT</b> (4 per package)	INX8099		

