

FA-14 RANGE LIGHT LONG RANGE SIGNALING LANTERN

The FA-14 range light is designed to provide a high peak intensity output for long range nighttime and daytime signaling applications. It provides reliable output under varying environmental conditions, adaptability to different signaling requirements including wireless synchronization, simple logistics, and long service life with reduced spare parts requirements.

With the increase in development in port areas, it is becoming increasingly more difficult to distinguish the leading lights from the background lighting. Increasing the candlepower of the light and rhythmically flashing the lights give some improvement but the random nature of the flashing limits effectiveness. Synchronization of the flashing leading lights is known to greatly increase the conspicuity of the lights but it is costly to have a hardwire synchronization connection between the two lights.

To increase the conspicuity of leading lines, Automatic Power has developed the wireless UNIFLASH-II system for synchronizing FA-14 leading lights. This system receives the Global Positioning System (GPS) satellite signals and uses the decoded signal to synchronize the flashing of the leading lines. This system is a cost effective solution to synchronizing leading lines worldwide.

The FA-14 housing is made of anodized aluminum which has proven to be an exceptionally durable material in the marine environment. The lantern opens to the front with the mirror attached giving access to the FLASHCHANGER. Electrical access is through 3/4" NPT threaded entries in the back of the lantern.

Using an APCL-5 FLASHCHANGER® frees up space in the FA-14 housing to mount a TR-3 Power Supply for AC application where 12Volt 0.25-3.05 amp lamps are required, or the GLOBALNAV controller for wireless UNIFLASH®-II synchronization of flashing range lights.

The two-station range is the most effective lighting system for marking restricted pilotage waterways. The lights of each station are aligned when the ship is on the channel's centerline. The lights separate when the ship drifts to either side. This feature gives the pilot a "feel" for his position off the range since he can tell the direction and degree of drift. Course corrections can be evaluated immediately by whether the lights begin to "open" or "close".

The single station, "polychrome (color-sectored) range, gives the pilot information that is limited to where he is at the current time--right, left or in the center of the channel. It may not give sufficient feedback for the pilot to determine if the ship's position is improving or worsening in order for him to make timely steering adjustments. The larger the vessel, the narrower the channel, the stronger the drift, the less effective the polychrome range.

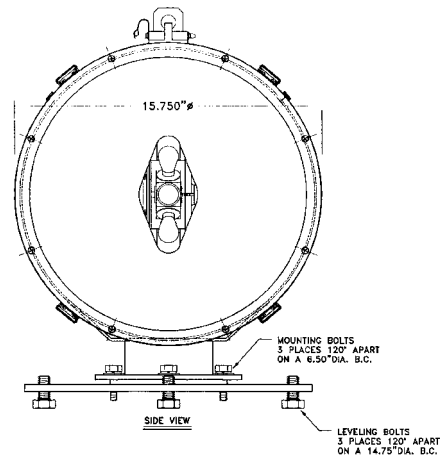
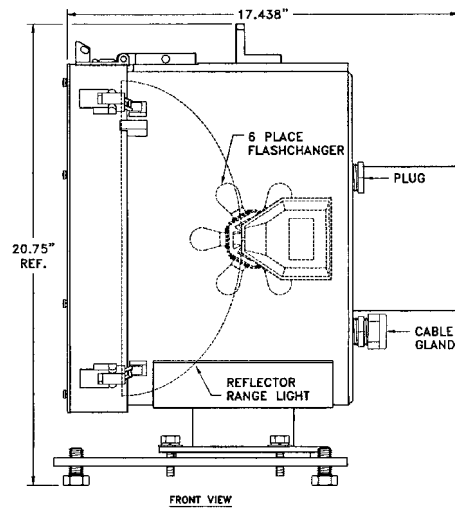

FA-14 RANGE LIGHT

OPTICAL PERFORMANCE

LAMP			FIXED INTENSITIES (Candela)
Filament	Volts	Amperes	Flatlite*
CC-8	12.0	1.0	197,000
CC-8	12.0	2.0	396,000
CC-8	12.0	3.0	491,000
C-8	12.0	9.00	1,400,000
C-8	12.0	35W	904,000
C-8	12.0	50W	551,000
C-8	12.0	75W	1,209,000
C-8	24.0	150W	880,000
ARC***	120	150 W	1,875,000

Note: For red lens multiply above by 0.30. For green lens multiply above by 0.32. For yellow lens multiply above by 0.68. *Candela measured on axis. ***Fixed Burning Only. Vertical Divergence 0.5°-1.2° to 10%. 3-degree, 8-degree, 11-degree, 20-degree, and 28-degree Spread Lenses for this optic are available from Tideland Signal Corporation.

TECHNICAL DATA

LENS:

Flatlight. Available in clear, red, green, and yellow.

FLASHCHANGER®:

Four- or Six-place motor driven, APCL-5/APCL-10 with selectable flash rhythms, pulsewidth modulation regulation, solar charge regulator, monitoring, synchronization, self-test function, communications port, lampout control terminal, photocell, and enhanced environmental protection. Interchangeable with CG-6P lampchanger.

LAMPS:

Prefocussed T3.5, S-8, or S-11 envelope and C-8 or CC-8 filament, incandescent or tungsten halogen lamps to 120 watts.

UNIFLASH® II:

Wireless synchronization system mounted in the FA-14 housing.

MATERIALS:

Acrylic lenses. Anodized aluminum housing, stainless steel fittings, silicone-rubber lens gaskets.

FINISH:

Grey.

ACCESSORIES:

Rifle-type aiming sights, Leveling and aligning adjustments in the base. Flat pad on top of unit for spirit level.. Photocell.

DIMENSIONS:

Height: 21 in X 15 in X 16 in. Weight: 28 pounds. Shipping Weight: 44 pounds.