

PX, BX & NX Strobes

Industrial Xenon Strobe Fixtures

Features:

- Heavy duty **polycarbonate fresnal lens** for maximum light concentration.
- **2 million peak candlepower** intensity, factory set at 60 FPM.
- **Electronic flashboards** are available in four **AC and DC voltages**.
- Cast **zinc aluminum** housing on "PX" & "BX" models.
- Cast models have **integral guard** for maximum lens protection.
- **Epoxy coat finish** for maximum corrosion resistance.
- **Low power consumption**.
- **Polycarbonate housing** on "NX" model is ideal for marine applications.

Applications:

- | | |
|----------------------------|---|
| ■ Evacuation signaling | ■ Oil drilling rigs (land and offshore) |
| ■ Mining facilities | ■ Waste water treatment plants |
| ■ Marine loading terminals | ■ Remote pipeline stations |
| ■ Plant safety stations | ■ Utility substations |

PX & BX - Strobe

Catalog Number Logic

PX - **M** - **1** - **R**
 (1) (2) (3) (4)

((1) Series - "PX" or "BX")

PX - Pendant mount 3/4" npt. hub industrial Xenon strobe.
BX - Base mount 1/2" npt. hub industrial Xenon strobe.

(2) Lamp Type (Xenon)

M - Medium intensity, 2 million candlepower

(3) Voltage / Frequency

1 - 125 Volt, 50/60 Hz.
2 - 240 Volt, 50/60Hz.
8 - 10 to 30 Volt DC
9 - 90 to 130 Volt DC

(4) Fresnal Lens Color

A - Amber
B - Blue
C - Clear
G - Green
R - Red

Note:

All fixtures shipped with lamp installed.

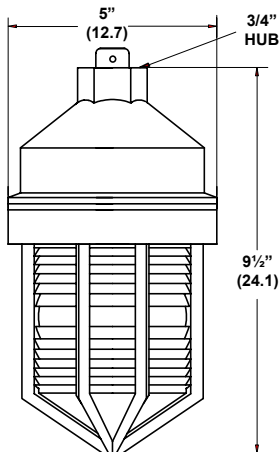

Shipping Volume ft ³ (m ³)	0.4 (0.012)
Shipping Weight lbs. (kg.)	1.6 (4.0)

Dimensions

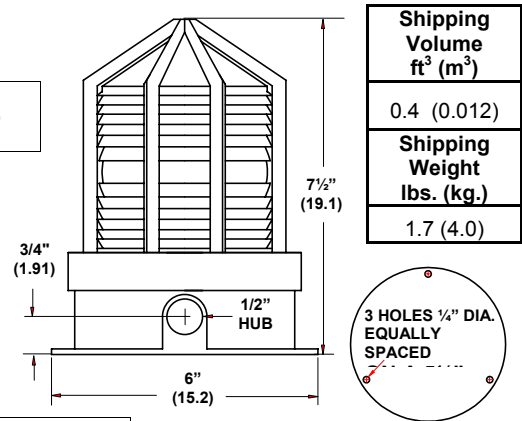

Shipping Volume ft ³ (m ³)	0.4 (0.012)
Shipping Weight lbs. (kg.)	1.7 (4.0)

Fixture Components

Strobe Components	Catalog #	Description	Weight lbs. (kg.)
	020-2011	Medium intensity flash tube (2 million candlepower)	0.1lbs (0.05)
	020-2001	Med. intensity 120 Volt AC, 50/60 Hz.	0.4 lbs (0.18)
	020-2003	Med. intensity 240 Volt AC, 50/60 Hz.	
	020-2008	Med. intensity 10 to 30 Volt DC	
	020-2010	Med. intensity 90 to 130 Volt DC	
	018-0210	Amber inner fresnel lens	0.2 lbs (0.1)
	018-0220	Blue inner fresnel lens	
	018-0230	Clear inner fresnel lens	
	018-0240	Green inner fresnel lens	
	018-0250	Red inner fresnel lens	

NX-Strobe

Catalog Number Logic

NX - **M** - **1** - **R**
 (1) (2) (3) (4)

((1) Series - "NX"

Non-metallic mount 3/4" npt. entry industrial Xenon strobe.

(2) Lamp Type (Xenon)

M - Medium intensity, 2 million candlepower

(3) Voltage / Frequency

- 1 - 125 Volt, 50/60 Hz.
- 2 - 240 Volt, 50/60Hz.
- 8 - 10 to 30 Volt DC
- 9 - 90 to 130 Volt DC

(4) Fresnal Lens Color

- A** - Amber
- B** - Blue
- C** - Clear
- G** - Green
- R** - Red

Note: All fixtures shipped with lamp installed.

Dimensions

Fixture Components

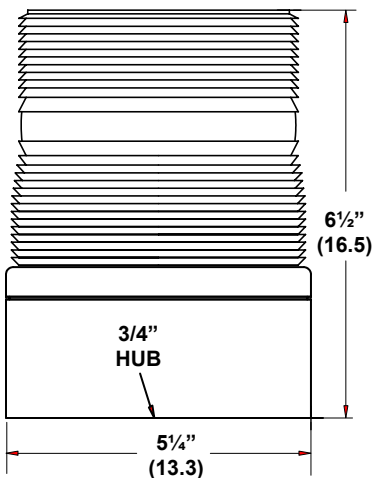

Shipping Volume
ft³ (m³)
0.4 (0.012)

Shipping Weight
lbs. (kg.)
1.7 (4.0)

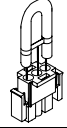
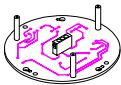
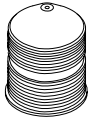
Strobe Components	Catalog #	Description	Weight lbs. (kg.)
	020-2011	Medium intensity flash tube (2 million candlepower)	0.1lbs (0.05)
	020-2001	Med. intensity 120 Volt AC, 50/60 Hz.	0.4 lbs (0.18)
	020-2003	Med. intensity 240 Volt AC, 50/60 Hz.	
	020-2008	Med. intensity 10 to 30 Volt DC	
	020-2010	Med. intensity 90 to 130 Volt DC	
	017-0210	Amber inner fresnel lens	0.2 lbs (0.1)
	017-0220	Blue inner fresnel lens	
	017-0230	Clear inner fresnel lens	
	017-0240	Green inner fresnel lens	
	017-0250	Red inner fresnel lens	